

CHICAGO FAUCETS

Last As Long As The Building

2100 SOUTH CLEARWATER DRIVE
DES PLAINES, ILLINOIS 60018-5999

FITTING NO.

748-003K

SUBMITTED MODEL NO.

JOB NAME

ITEM NO.

SUBMITTED AS SHOWN

SUBMITTED AS NOTED

SEE ATTACHED FOR
SUBMITTED MODIFICATION

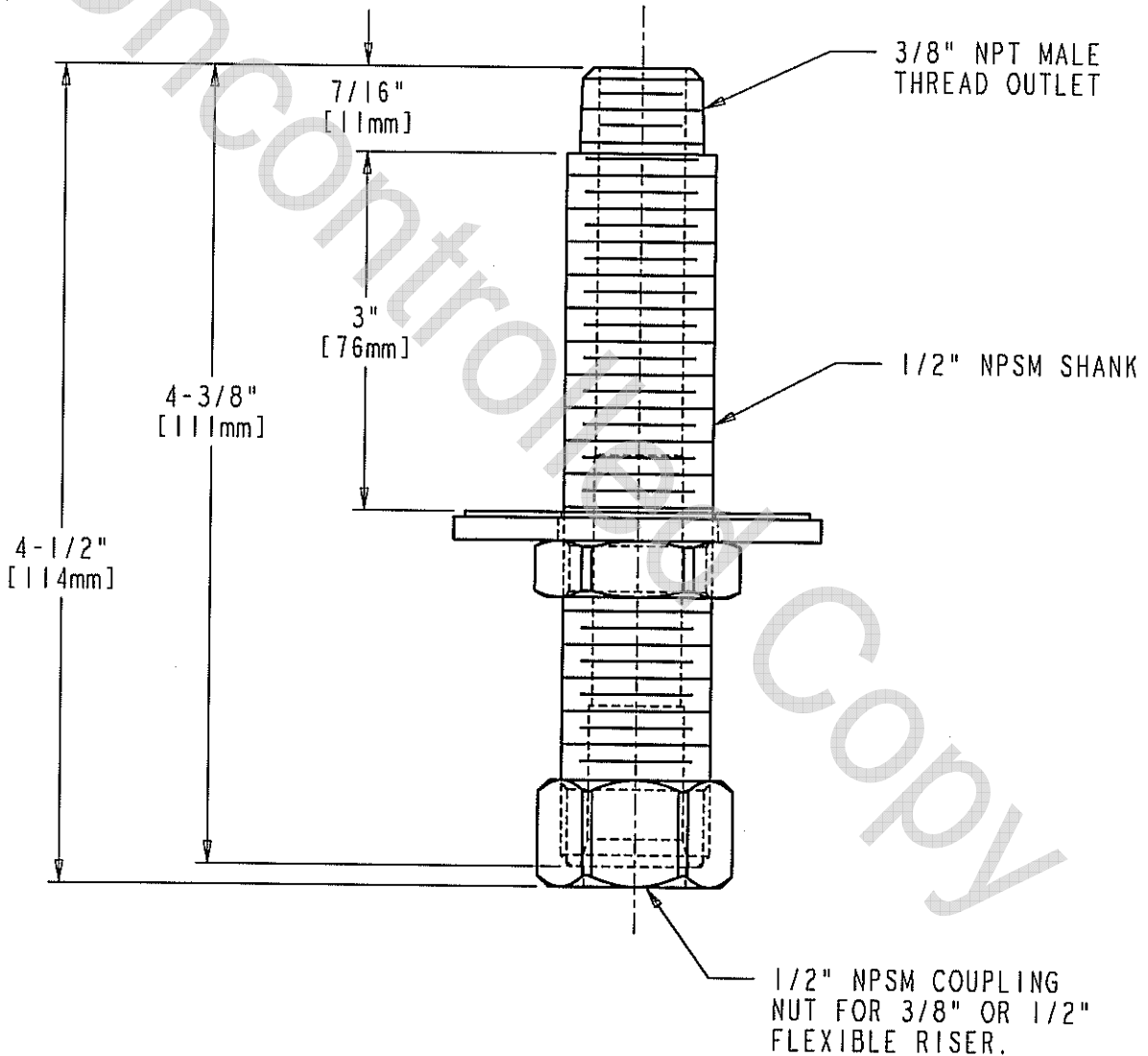

DIMENSIONS IN INCHES AND [MILLIMETERS].

TECHNICAL DATA

- INLET SHANK WITH LOCKNUT AND WASHER

DATE: 7-16-02

BY: JAR

CHK'D: *AT*

APP'D:

REV: A

748-003K

ROUGHING IN DIMENSIONS MAY VARY AND ARE SUBJECT TO CHANGE. NO RESPONSIBILITY IS ASSUMED FOR USE OF SUPERCEDED OR VOIDED DATA.